

Rotomaxx™



High Torque, High Flow, Right Angle Mixers

Advanced Mixing Technologies

Built to sanitary standards at a competitive price

For larger tank volumes requiring rapid turnover & high efficiency agitation, but also designed to meet stringent CIP washdown, pressure washing and steam cleaning conditions. The Rotomaxx is available in both a Pharmaceutical or a Food grade, all stainless configuration, with multiple output speeds and seal combinations. Our Jetfoil™ impeller technology provides 200% of the pumping rate found on conventional axial blade impellers..



Big performance in a compact package

- ✓ Total washdown capability with  TPV (#73-01) compliance
- ✓ Tank Volumes to 10,000 gallons
- ✓ Pumping Rates to 20,000 GPM
- ✓ 1/2 to 3 HP, 30-235 RPM output speeds
- ✓ Right angle design for low headroom space
- ✓ Available with direct readout of shaft speed through internal or external proximity sensors
- ✓ Validation documentation & factory acceptance testing (FAT) for GMP and FDA requirements

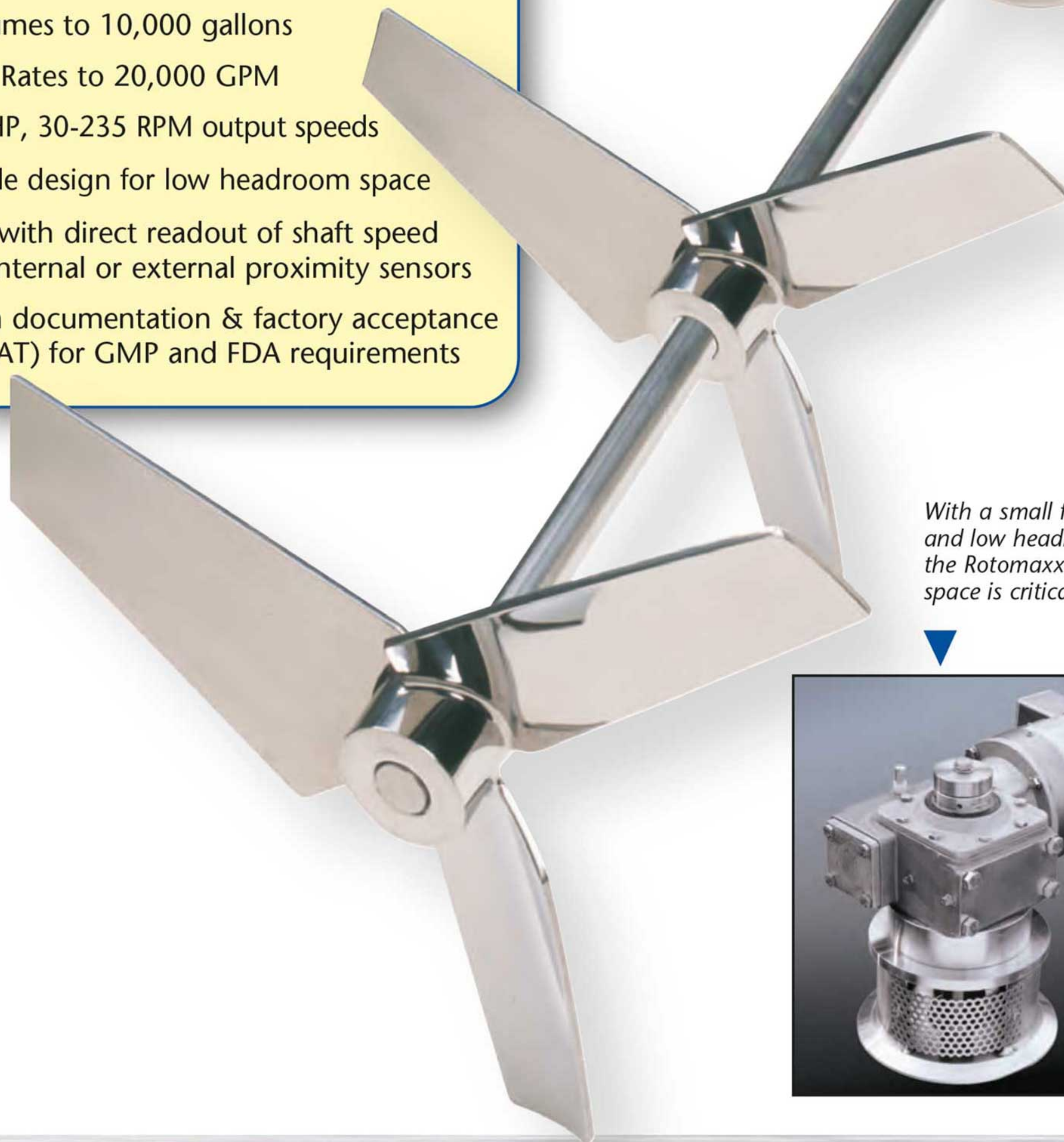

With a small footprint and low headroom design, the Rotomaxx is ideal where space is critical on large tanks



Your Mixing Technology Partner . . . www.admix.com

Rotomaxx Specifications

The Rotomaxx series of stainless steel mixers are available in three (3) basic configurations as shown below:

Mixer Model	125 RMAX	150 RMAX	200 RMAX
Output Speed (RPM)	30-235	30-235	30-235
HP Range	1/2 - 2	1/2 - 3	3/4 - 3
Shaft Diameter	1-1/4"	1-1/2"	2"
Maximum Shaft Length	up to 95"	up to 106"	up to 165"
Foil Diameter	up to 55"	up to 65"	up to 67"
Pumping Rate @ 1 cps (GPM)	up to 13,000	up to 20,500	up to 23,800

Rotomaxx

	A	B	C	D	E	F	G	H
125RMAX	8.7	1.25	18	3.3	7.7	12	7.9	1.00
150RMAX	9.1	1.50	19	4.4	9.4	12	7.9	1.25
200RMAX	10.4	2.00	20	5.5	11.8	12	7.0	1.00

Dimensions are in inches

C & E may vary with motor selection

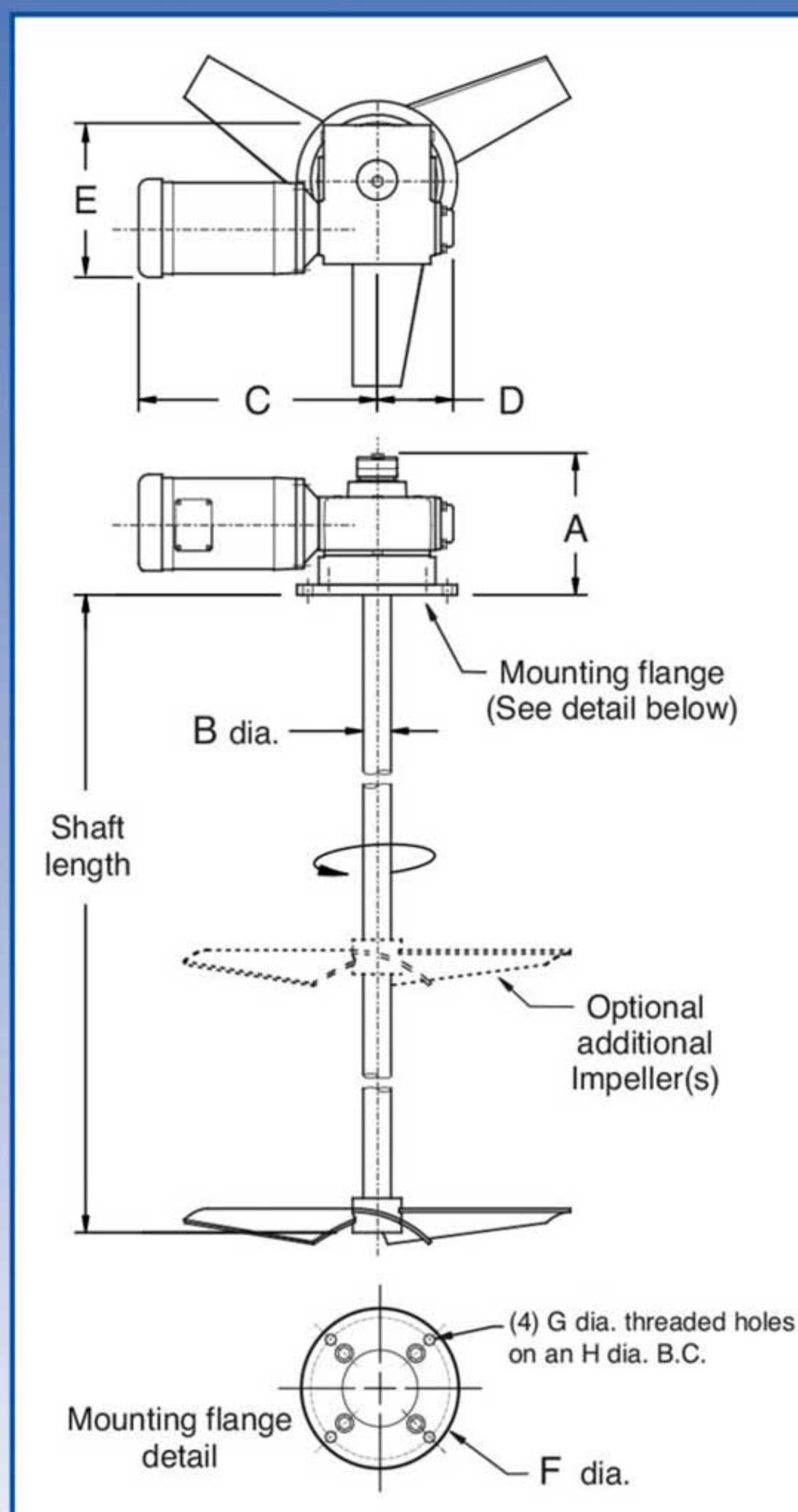

For more information:

EMPLOYEE OWNED...
CUSTOMER FOCUSED

Ease of Installation & Service

The modular design of the Rotomaxx components, along with the hollow quill bore of the reducer, allows for easy mounting and servicing.

SS Motors are directly coupled to eliminate misalignment.

SS Gear Reducers include a hollow bore to eliminate shaft couplings.

SS Pedestals allow easy seal disassembly and are registered for perfect seal alignment.

Removable SS Shaft is both keyed and retained above the hollow quill to eliminate slip.

SS Jetfoil™ Impellers are keyed, welded or can be bolted construction where space is limited.

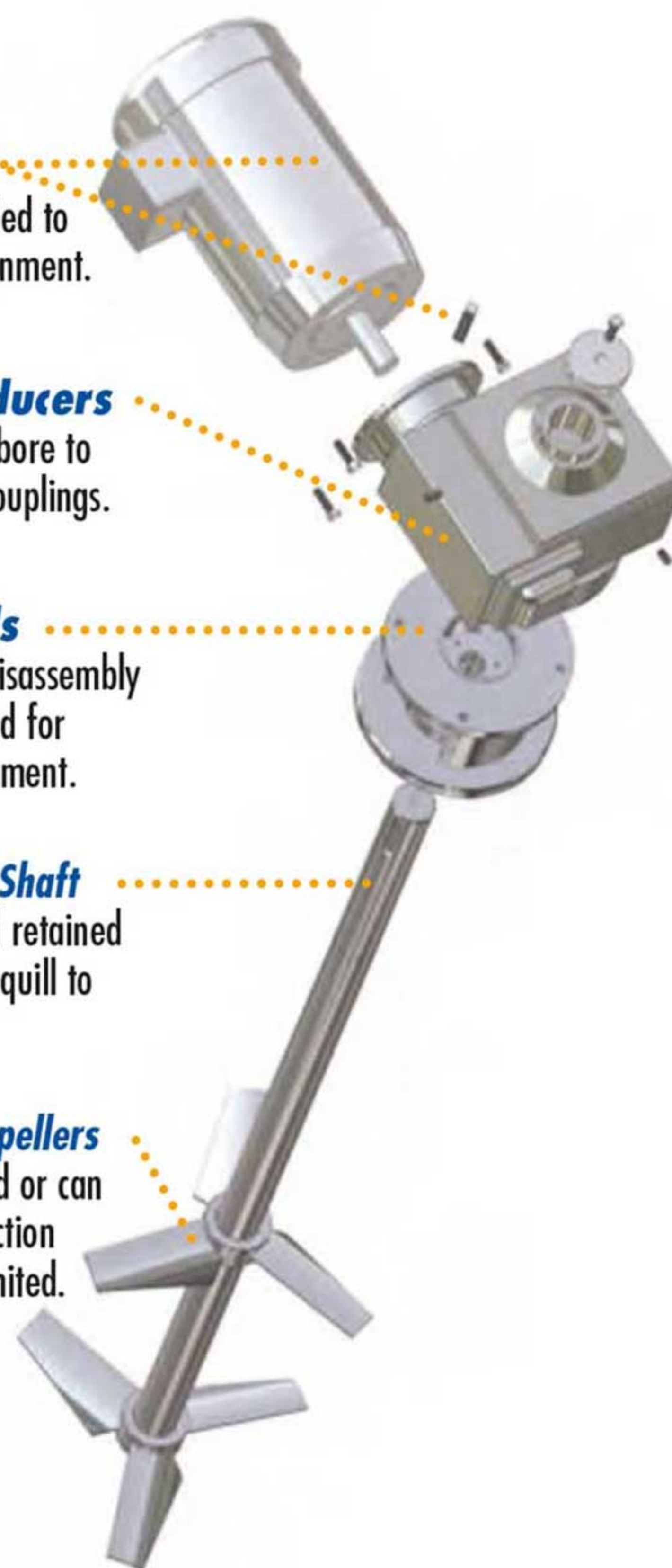

Selection & Performance

Selection of the proper Rotomaxx model for your application is simplified with our **MixxScale** sizing criteria. Our **MixxScale** program utilizes bulk fluid velocity and impeller size (foil diameter to tank diameter ratio) to provide the desired level of agitation, suspension of solids and top-to-bottom flow control. Our high efficiency Jetfoil™ impellers provide maximum performance using the lowest horsepower consumption and an optimized gearbox size to reduce overall costs.

Our **MixxScale** (MS) selections range from 1 through 4 with MS = 1 providing a lower level of agitation with little vortex and longer blend times (10-30 minutes), while MS = 4 is characterized by very vigorous agitation with excellent suspension and very rapid blend times of under 10 minutes. The following tables provide the best Rotomaxx selection for the designated level of agitation, tank volume and viscosity.

MixxScale of 1

VOLUME	VISCOSITY			
	10	500	1,000	5,000
10,000	<div style="background-color: #00a0e3; color: white; padding: 5px; text-align: center;">200 RMAX</div> <div style="background-color: #0056b3; color: white; padding: 5px; text-align: center;">150 RMAX</div> <div style="background-color: #e91e63; color: white; padding: 5px; text-align: center;">125 RMAX</div>			
7,500				
5,000				
2,500				
2,000				
1,500				
1,000				

MixxScale of 2

VOLUME	VISCOSITY			
	10	500	1,000	5,000
10,000	<div style="background-color: #00a0e3; color: white; padding: 5px; text-align: center;">200 RMAX</div> <div style="background-color: #0056b3; color: white; padding: 5px; text-align: center;">150 RMAX</div> <div style="background-color: #e91e63; color: white; padding: 5px; text-align: center;">125 RMAX</div>			
7,500				
5,000				
2,500				
2,000				
1,500				
1,000				

MixxScale of 3

VOLUME	VISCOSITY			
	10	500	1,000	5,000
10,000	<div style="background-color: #00a0e3; color: white; padding: 5px; text-align: center;">200 RMAX</div> <div style="background-color: #0056b3; color: white; padding: 5px; text-align: center;">150 RMAX</div> <div style="background-color: #e91e63; color: white; padding: 5px; text-align: center;">125 RMAX</div>			
7,500				
5,000				
2,500				
2,000				
1,500				
1,000				

MixxScale of 4

VOLUME	VISCOSITY			
	10	500	1,000	5,000
10,000	<div style="background-color: #00a0e3; color: white; padding: 5px; text-align: center;">200 RMAX</div> <div style="background-color: #0056b3; color: white; padding: 5px; text-align: center;">150 RMAX</div>			
7,500				
5,000				
2,500				
2,000				
1,500				
1,000				

Printed in USA ROTOMAXX-2/15

www.admix.com ■ 800-466-2369



144 Harvey Road ■ Londonderry, NH 03053