

ULMA

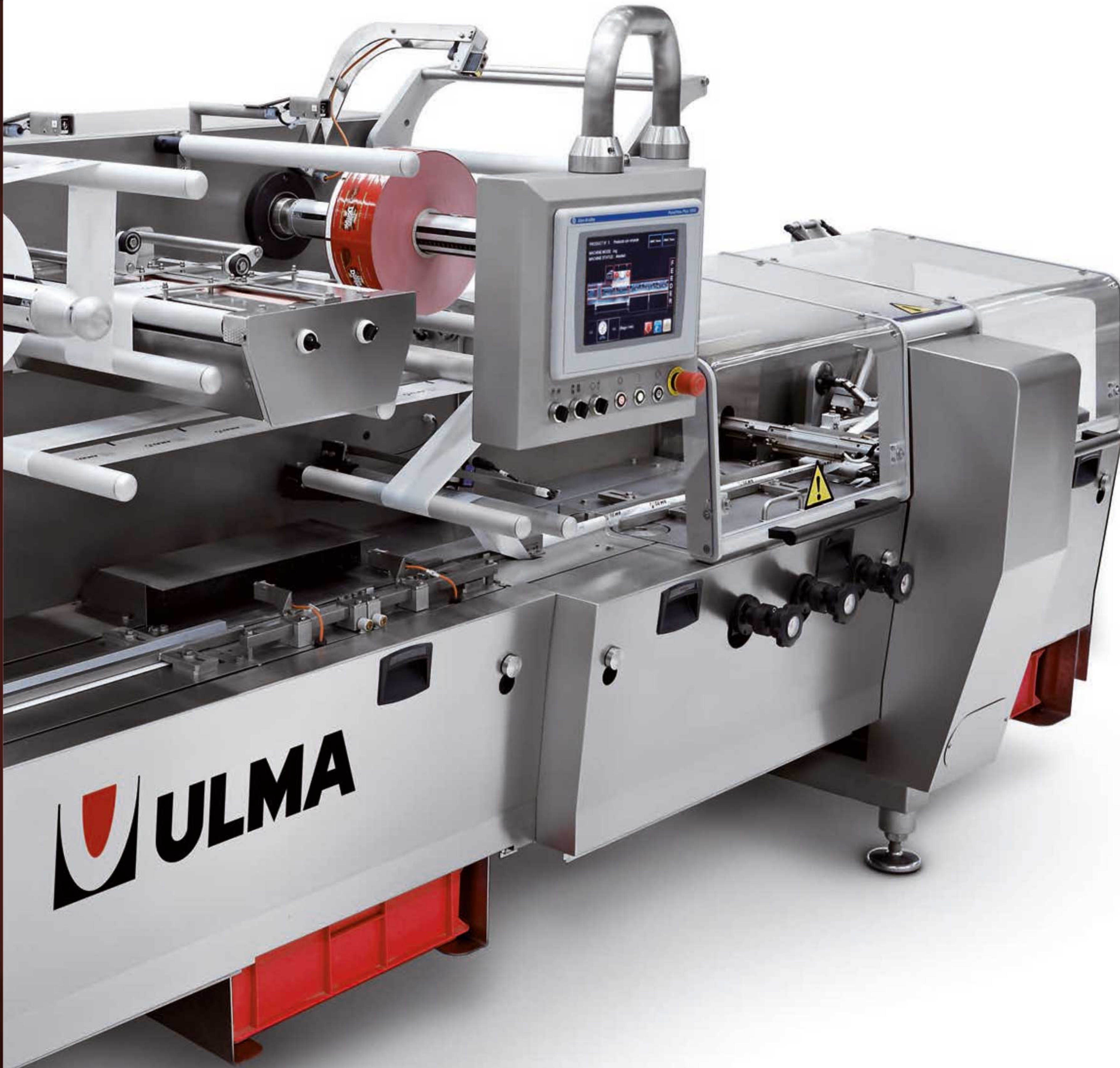

FR 500
Flow Pack

Horizontal flow wrapping machine

The FR 500 machine represents the highest technology model in the range of ULMA horizontal wrappers.

Fully electronic, it integrates a multi-axis electronic control which synchronizes machine's main movements.

It is specially designed to be integrated into packaging systems in applications with medium and high speed productions.

The model FR 500 is complete with different feeders and autoloaders designed mainly for bakery and chocolate products.



FR 500



HMI panel with color graphics



Cross cut sealing system with 2 jaws per shaft



Double film roll holders with automatic roll splicing



Horizontal flow wrapping machine

TECHNICAL CHARACTERISTICS

- ▶ Stainless steel and cantilever construction.
- ▶ Electronic machine equipped with four independent servomotors (rotary jaws, sealing rollers, infeed conveyor and motorized reel holder) synchronized by an electronic multi-axis control)
- ▶ Four pairs of sealing rollers.
- ▶ Automatic reel splicing.
- ▶ Pneumatic fastening of film reel.
- ▶ 10" color touch screen to adjust machine parameters, diagnostics and reporting.
- ▶ Infeed conveyor with chain at one side.
- ▶ Top motorized belt system at exit belt.
- ▶ Empty and mis-cut package rejecter.
- ▶ Complete range of infeed conveyors depending on the application and product.

MAIN OPTIONAL ELEMENTS

- ▶ Printing system.
- ▶ Cold plate sealing rollers.
- ▶ Overhead and side devices.
- ▶ Aspiration system between rollers.
- ▶ "D-Cam" type jaw.
- ▶ Gusseting device by mechanical or air system.

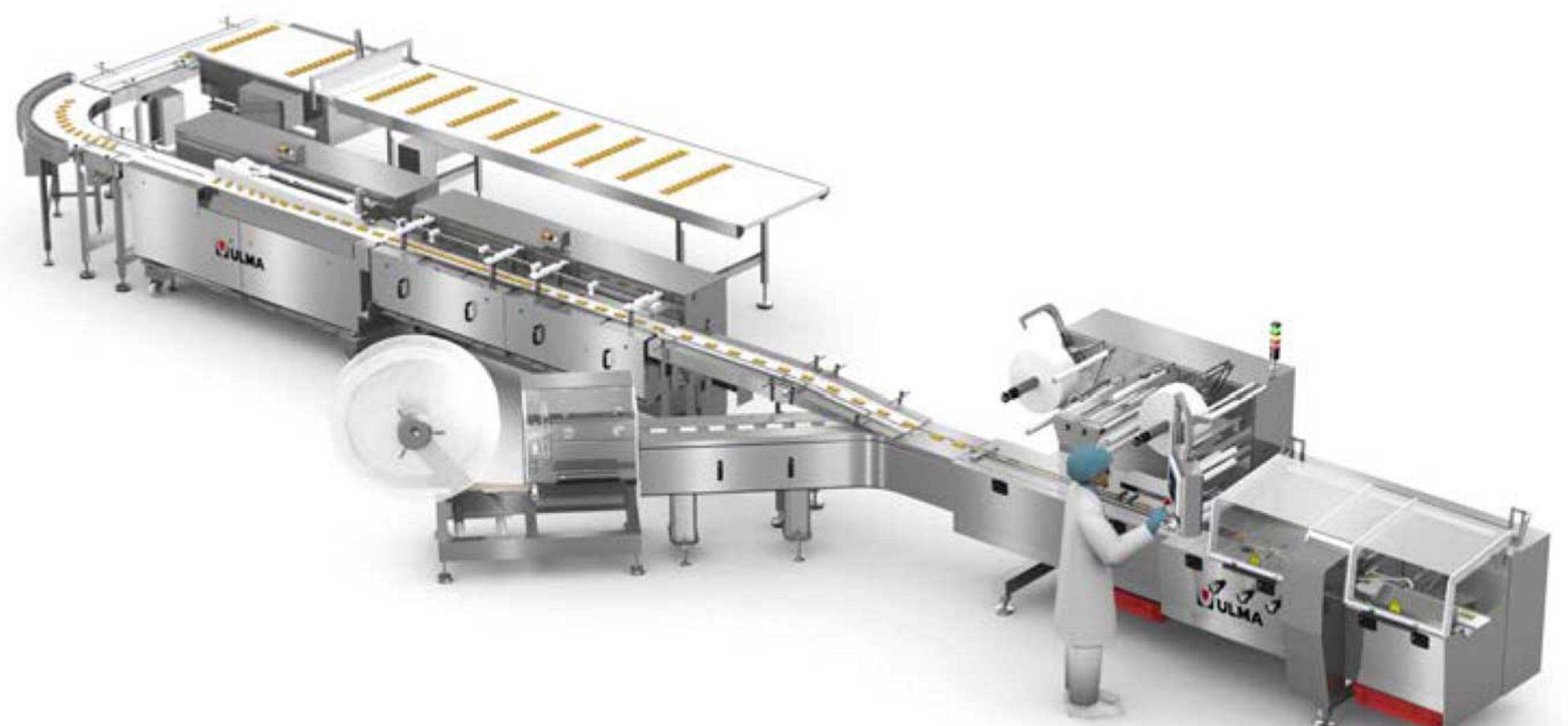
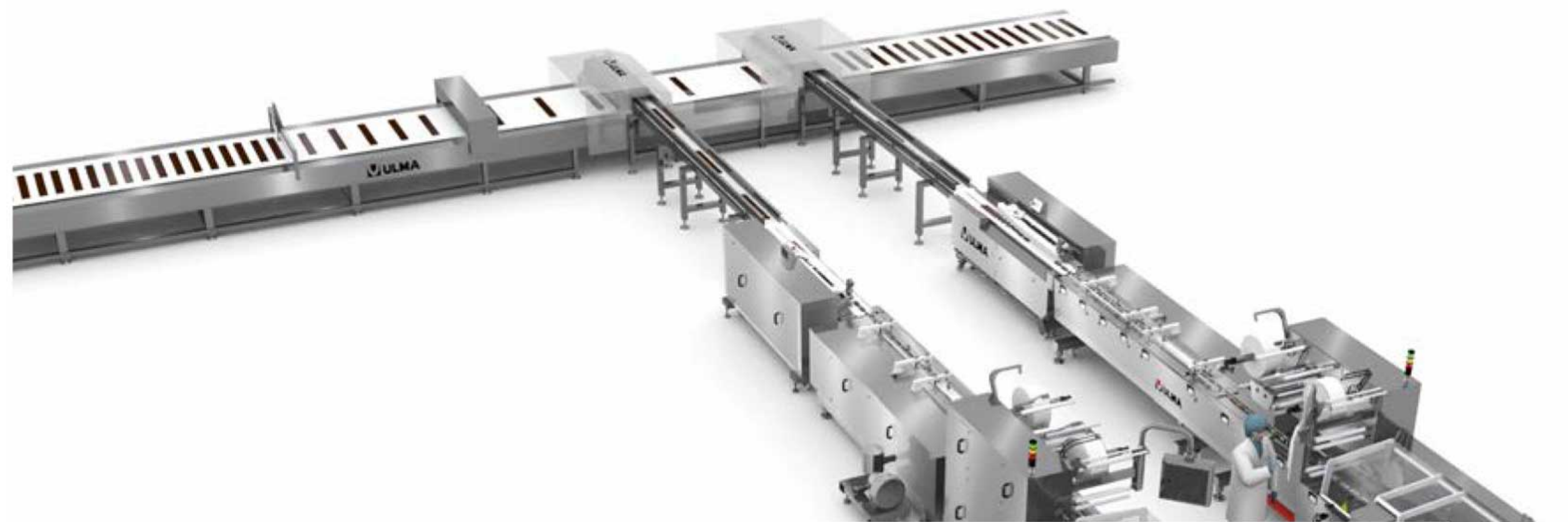

Misplaced product rejecter in the infeed conveyor



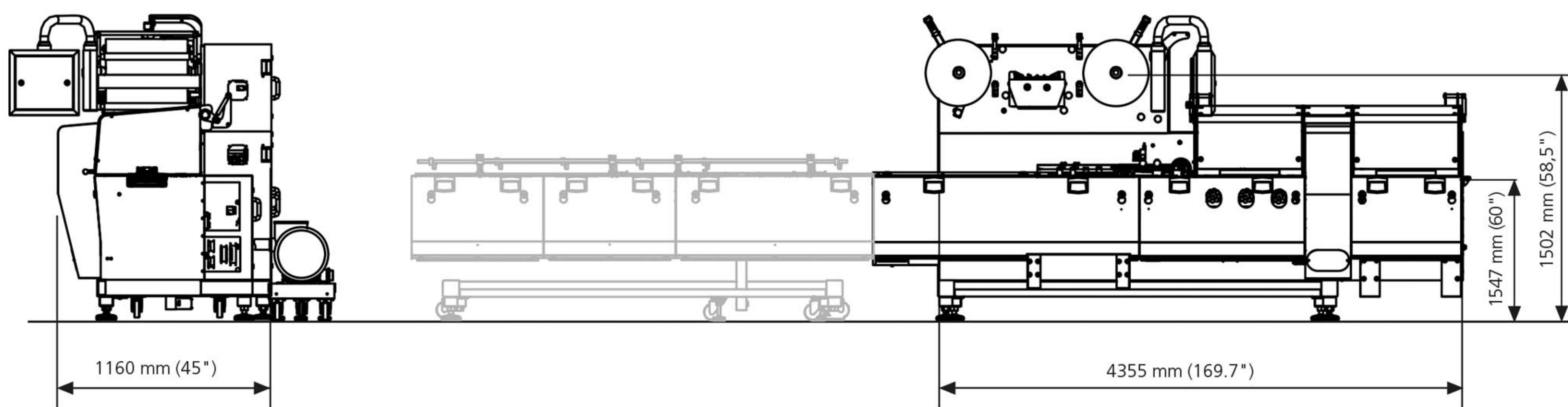

TECHNICAL SPECIFICATIONS

PRODUCT DIMENSIONS: <i>(All maximum or all minimum dimensions may not be attainable at the same time) (Consult ULMA for other dimensions)</i>	Seal jaw diameter	Ø 144 mm (5.7")	Ø 200 mm (7.9")
	Bag length	90 - 450 mm (3.5" - 17.5")	125 - 625 mm (5" - 24.5")
	Product length	60 - 350 mm (2.4" - 13.75")	90 - 500 mm (4.9" - 19.5")
	Product width	10 - 250 mm (4" - 9.75")	10 - 250 mm (4" - 9.75")
	Product height	5 - 70 mm (1/4" - 2.75")	5 - 150 mm (1/4" - 6")
SPEED	<i>(all maximum and minimum dimensions can not attain maximum speed)</i>	Up to 800 packs/min. - 80 m /min. (262' /min.) <i>(dependent on product type, dimensions, and film type)</i>	
PACKAGING MATERIAL	Heat sealable films: BOPP (Bi-Oriented Polypropylene), PVC, polyester, cellulose, Cold sealing films / Versions for: Polyolefin shrinkable films, HDPE, laminated films		
FILM WIDTH CAPACITY	500 mm (op. 700 mm) (19.5") (op. 27.5")		
MAXIMUM ROLL DIAMETER	300 mm (12")		
CORE DIAMETER	76 mm (3")		
ELECTRICAL SPECIFICATIONS	Voltage	230 / 400 V Three-phase ±10% + Neutral + Ground – 50/60 Hz	
	Power consumption	8 kW - 16 Amp. / 380 V. • 14 Amp. / 230 V. (standard version)	
PNEUMATIC CONSUMPTION	From 0 to 50 l/m (0 to 1.75 CFM) / 6 bar (90 PSI) (depending on version and options)		
APPROXIMATE WEIGHT	1100 kg (2420 lb)		

ULMA reserves the right to change specifications without prior notice.



ULMA Packaging

Thanks to 50 years' experience, we are a worldwide reference in the design and manufacturing of high-technology packaging equipment and systems.

50 years of progressing, innovating and perfecting our technology and services. A wide network at your service to offer you solutions all over the world and to give full satisfaction to anyone who places his trust in us.

For more information, please see our website:

www.harpak-ulma.com