

TWISTER

Dicing, cutting strips, grating – everything is possible with TWISTER

In one hour the dicer achieves a max. output of up to 3,500 kg (theoretical maximum value), even during constant operation.

TWISTER is where highest durability and strong performance results meet great ease of operation from loading to cleaning. The simple display menu guiding is intuitive.

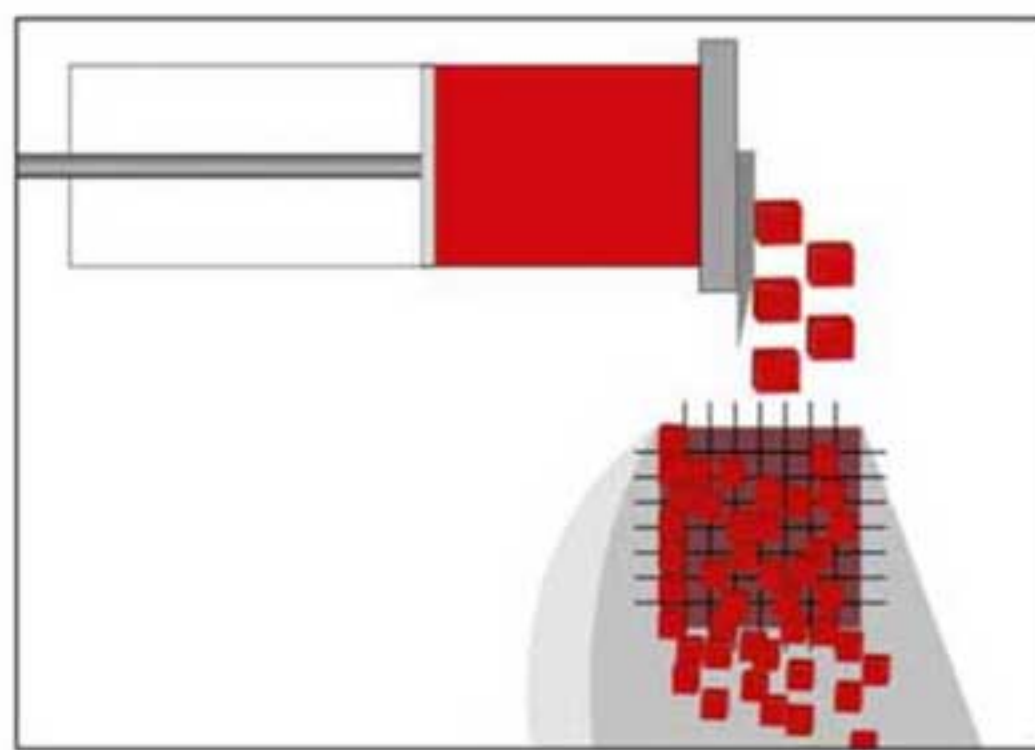

The AVS (automatic pre-compression system) facilitates an optimal dimensional accuracy of the cubes and strips right from the beginning. It also serves to optimise cycle times through, for example, faster movements in unfilled chamber sections.



Goulash cubes are of course part of the cutting repertoire of the TWISTER.

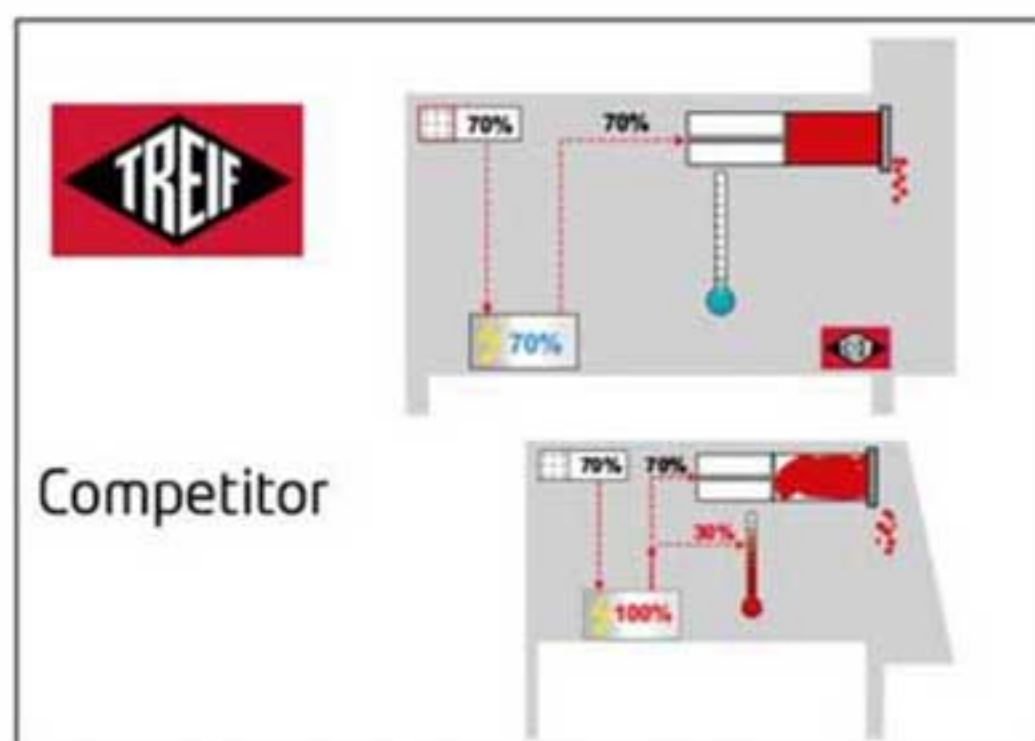

Competitor

As a result of the DHS (Dynamic Hydraulic System), the cut products stay fresh longer (the machine generates less heat, so there is less of a chance for bacteria to form).



Cooked products can also be cut with ease.



The separating slide operates in a curving motion. This is the only way to enable the convenient one-hand operation and fill the chamber to the maximum level.



TWISTER is very versatile. The different cutting parameters can be saved (up to 50 cutting programs).

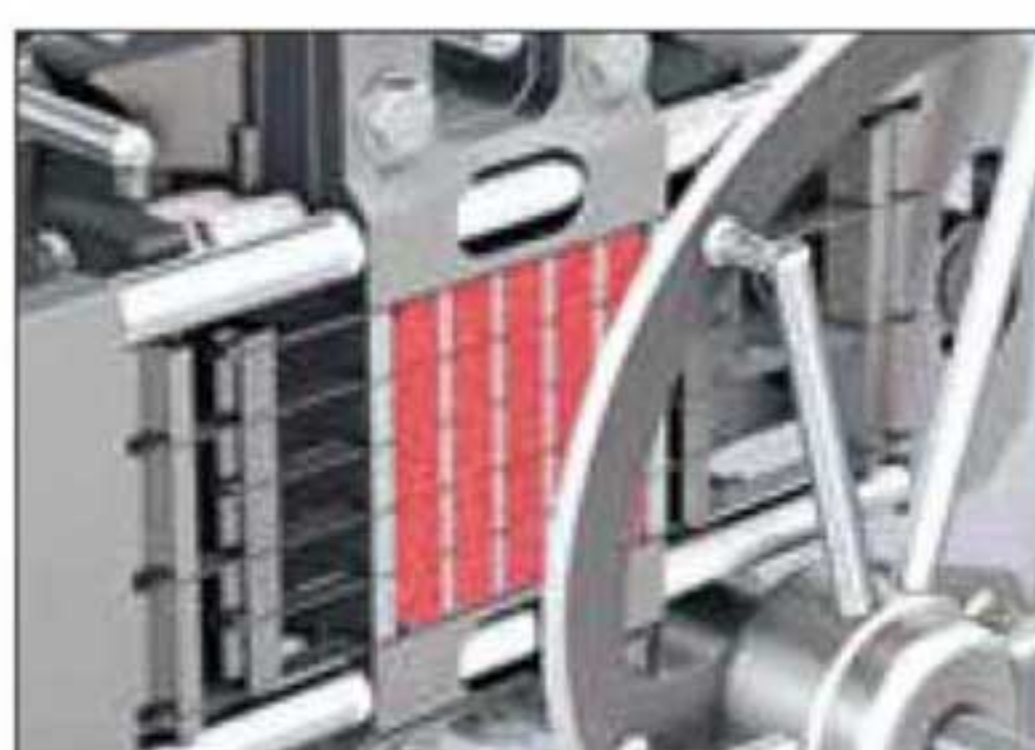

Excellent cutting results thanks to the patented gentle cut gridset (optional). This ensures the best possible cutting geometry for excellent cutting results.



The dicer can process up to 3.5 t in one hour (theoretical maximum value). The blade revolution speed can be individually set.



Gentle cut

With the help of the gentle cut gridset (optional), delicate products such as cooked meat, poultry or boiled sausage are cut gently, thus achieving excellent cutting results.

Technical data:

Max. output t/h (Theoretical maximum value)	3.5; 7,716 lbs
Max. cut-off length (mm/inch)	1-50; 1/25"-2"
Max. cut-off blade speed/min.	300/ 400 (optional)
Housing dimensions (mm/inch)	
Length / Width / Height (mm/ inch)	1,902/1,800/1,282; 74 4/5"/71"/50 1/2"
Connecting load (kW)	4,5 / 6,0 (optional)
Gridsets (mm/inch)	4/5/6/8/10/12/15/17/20/ 24/30/40/60/120 1/5"; 3/10"; 2/5"; 1/2"; 3/5"; 7/10"; 4/5"; 1"; 1 1/5"; 1 3/5"; 4 7/10"
Weight (kg/lb)	approx. 670; 1,477
Product specific accessoires	on request

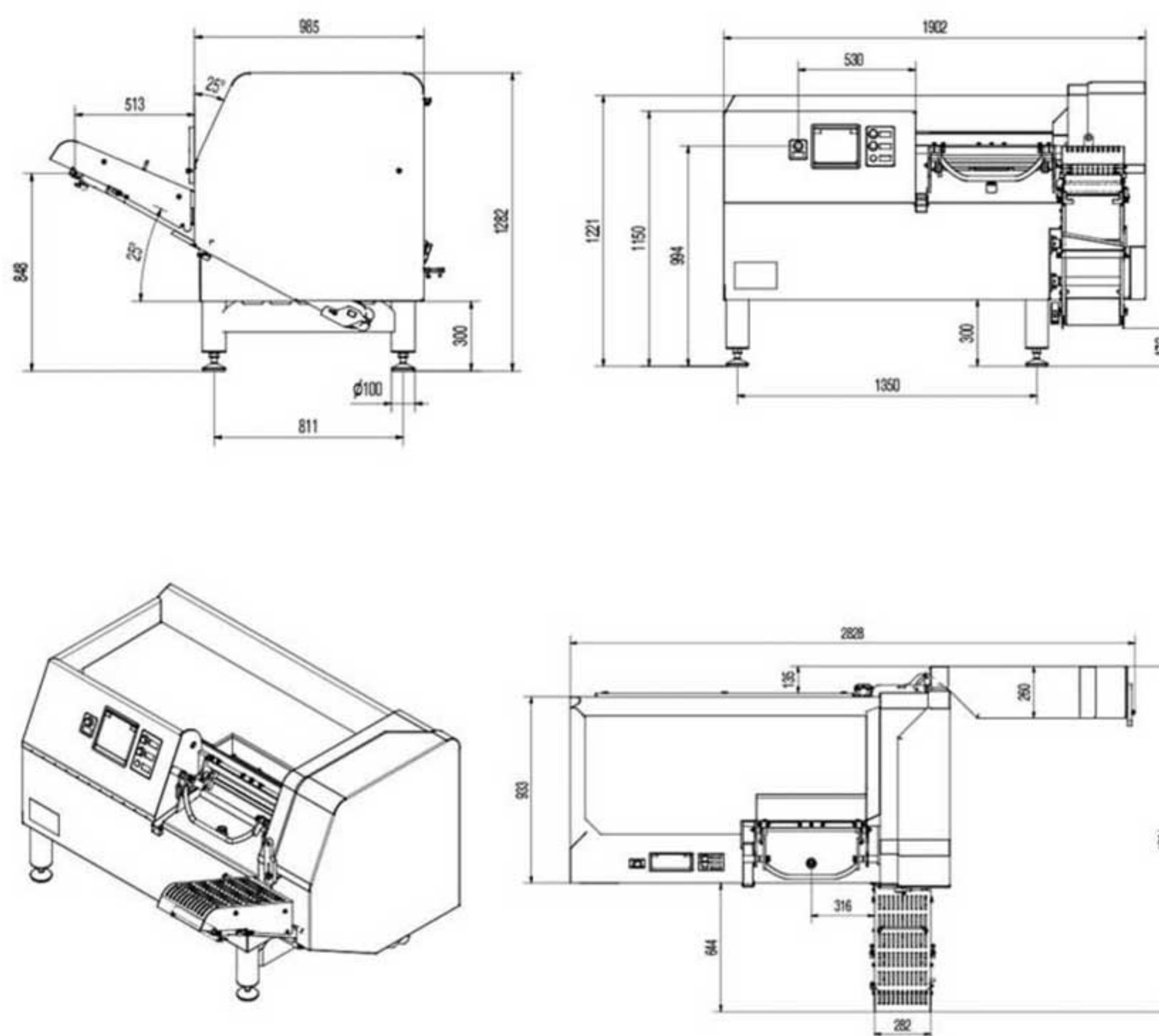

All measurements in mm.

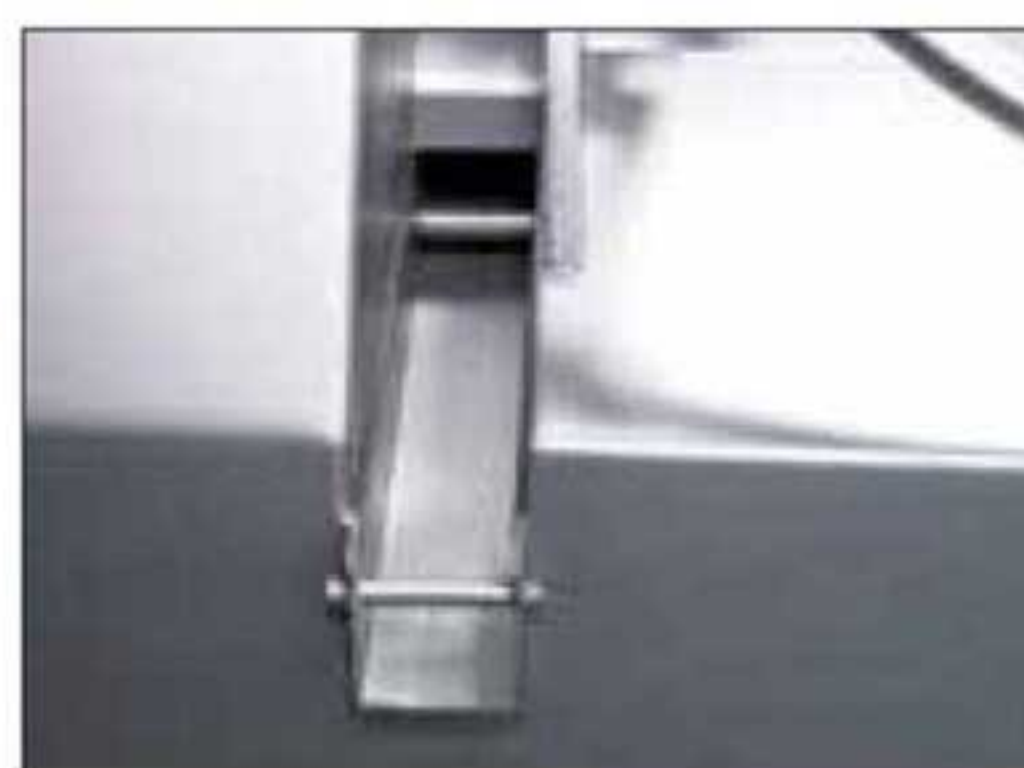

Cleaning channel for a better flow of liquids, e.g. meat juice, rinsing water.



For dicing cheese a special cheese grid is used.



TWISTER can also be fitted with a scale.

Your benefits at a glance:

- Flexibility and top performance thanks to continuous and intermittent cutting options and the ability to individually set the blade speed
- The standard guide key in the discharge belt prevents the belt from running out of line, extending its service life
- Optimum product compression as a result of the automatic pre-compression system (AVS)
- Simplification of data backup due to USB connection (standard)
- Ergonomic, one-hand operating system for closing the loading chamber; chamber size: 550 x 120 x 120 mm / 21 7/10" x 4 7/10" x 4 7/10" (length x width x height)
- Patented gentle cut gridset for delicate products (optional)
- Reliable protection against the hydraulic oil of the feed cylinder entering the cutting chamber; hygiene cylinder (optional) makes product contamination with hydraulic oil (only foodstuff hydraulic oil is employed at TREIF) technically impossible

Subject to modifications for technical progress. 0.25 12/2016 DieDruckerei

HEADQUARTERS:

TREIF Maschinenbau GmbH
Toni-Reifenhäuser-Str. 1
D-57641 Oberlahr
Phone +49 2685 944 0
Fax +49 2685 1025
E-Mail: info@treif.com

Further LOCATIONS:

TREIF U.K. Ltd.
Genesis House, Poole Hall Road
Poole Hall Industrial Estate
Ellesmere Port, GB-Cheshire CH66 1ST
Phone: +44 (0) 151 3506100
Fax: +44 (0) 151 3506101
E-Mail: treifuk@treif.com

TREIF USA Inc.
50 Waterview Drive, Suite 130
Shelton, CT 06484
Phone: +1 203 929 9930
Fax: +1 203 929 9949
E-Mail: treifusa@treif.com

Belgium China France Italy Russia

www.treif.com



DESCUBRE MÁS EN

www.taglermaq.cl