



## SIRIUS+

### Better slicing technology, new design, less weight: The new SIRIUS+

As a table model, the **SIRIUS+** stands out not only on account of its compact size. The universal bread slicer features a durable, yet lightweight construction as well as the revolutionary, clever hygiene design.

The lower weight is not the only difference between the SIRIUS+ and its predecessor SIRIUS, but also the optimised slicing technology for better placement and bagging of the slices. Best ergonomics thanks to optimum insertion height.



The rotary switch can be used to adjust the slice thickness between 4 and 14 mm and to halve loaves.



The blade manufactured at TREIF features a special coating and purpose-designed toothing. TREIF is the only manufacturer of bread slicing machines to produce its own blades.



After halving a loaf, the cut bread stops at the slicing level, allowing the halved bread to then be sliced to the exact desired thickness.



The innovative and easy-to-operate gripper ensures that only a minimum piece remains.



SIRIUS+ is the only table machine with an automatic slice support to support the slices during the cutting process, facilitating removal of the sliced bread. After removal, it swivels back automatically.



The excellent hygiene concept means that all small residue is collected in the tray, which is easily removed. The crumb drawer can be emptied and swept out in no time at all.



A look into the bread removal area shows how hygienic the SIRIUS+ is. The numerous crumb slots facilitate cleaning. Simply sweep out - finished!

The larger feed shaft allows even large round loaves to be halved and sliced.



## SIRIUS+: The small one for great slicing results

Like all TREIF bread slicers, it requires no blade oiling at all.

TREIF was named a premium brand in the area of bread slicing machines.

### Technical data:

Max. slices/minute	100
Slice thickness (mm/inch)	4/5/6/7/8/9/10/11/12/14 1/5"-11/20" without 1/2", in steps of 1/25"
Cross section of product (mm/inch)	330 x 140 (in the middle 150) 13" x 5 33/64" (in the middle 6")
Infeed length (mm/inch)	400 / 15 4/5"
Automatic loaf-halving	✓
Housing dimensions (mm)	
Width/Depth/Height (mm/inch)	800/690/580 31 1/2" / 27 11/64" / 22 53/64"
Operating voltage	400 V, (230 V optional with a surcharge)
Pre-fuse in the supply line	10 A
Connecting load (kW)	0,9
Weight (kg/lb)	approx. 120 / 265
Underframe	optional

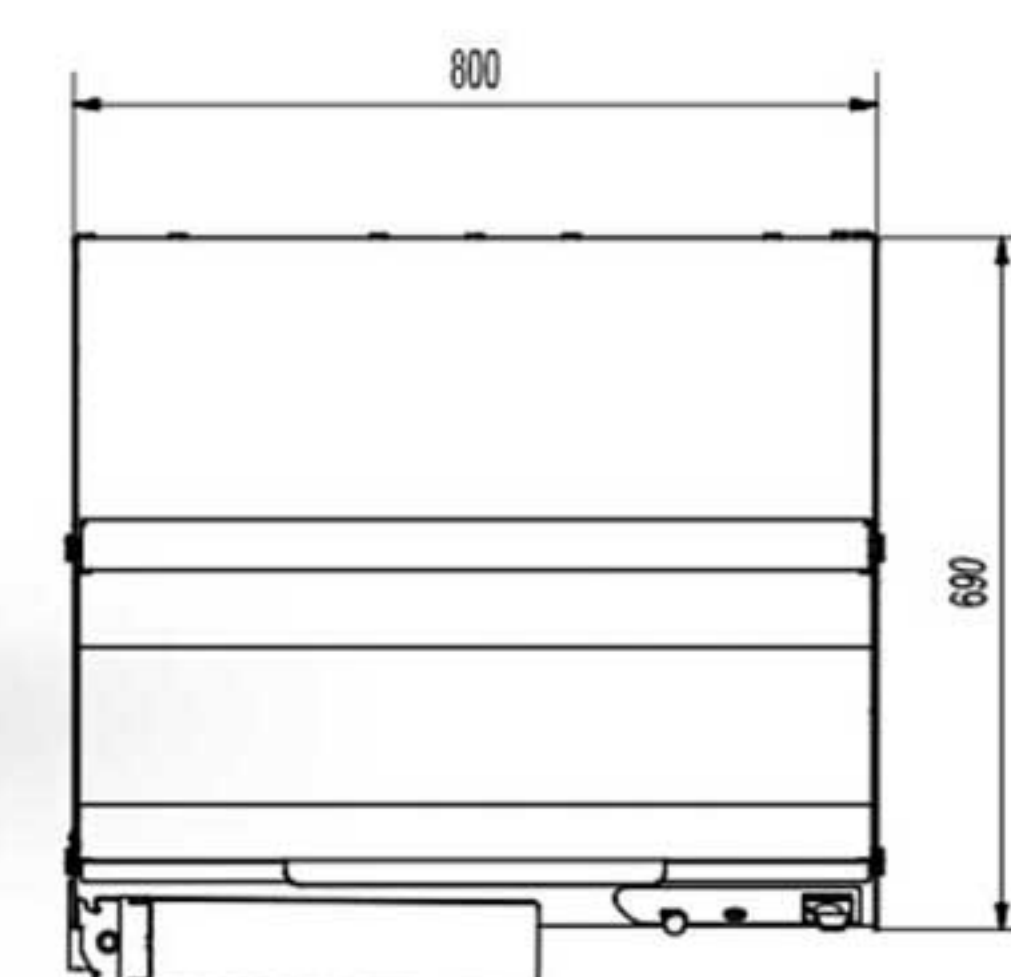
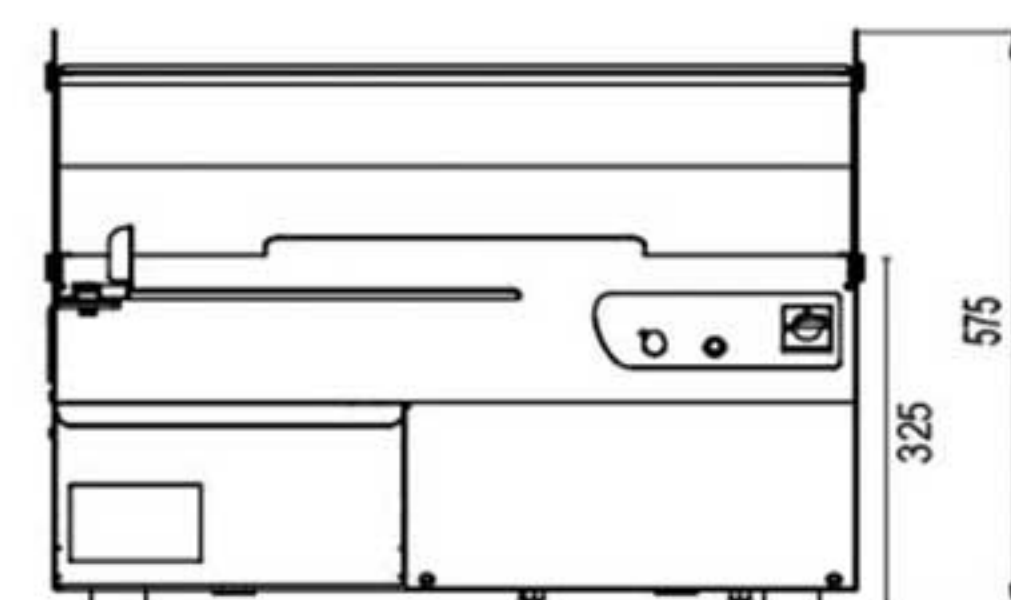

All measurements in mm.



The SIRIUS+ universal bread slicer can slice all bread types, from soft white bread to twice-baked bread with a hard crust (even fresh from the oven).



Clever design down to the last detail: The patented slicing gap cover ensures optimum placement of the bread and also reduces cleaning significantly.



Even easier handling: The SIRIUS+ is approx. 20% lighter than the previous model!

### Your benefits at a glance:

- Universal bread slicing machine: Slices all types of bread up to a length of **400 mm (fresh from the oven)**
- **Round loaves up to 330 mm diameter** can be halved and sliced without problems
- **Table model: compact design**, e.g. also suitable for vending vans/mobile bakeries (or optionally with movable support frame for the shop area)
- Very easy cleaning thanks to additional crumb slots in **the bread removal area**
- Significantly less cleaning effort thanks to **omission of blade oiling**
- Variable slice thickness, loaf halving with subsequent slicing
- Maximum ergonomics through **new optimum insertion height**
- **Robust and still lightweight:** the SIRIUS+ is designed for durability to the last detail
- Maximum service life of the circular blade thanks to **in-house blade manufacturing (nanoBlade)**; easy blade cleaning without dismantling

**nanoblade**  
TREIF blade manufacturing

Subject to modifications for technical progress. 0.25 03/2019 DieDruckerei

#### HEADQUARTERS:

TREIF Maschinenbau GmbH  
Toni-Reifenhäuser-Str. 1  
D-57641 Oberlahr  
Tel. +49 2685 944 0  
Fax +49 2685 1025  
E-Mail: info@treif.com

#### LOCATIONS:

TREIF USA Inc.  
50 Waterview Drive, Suite 130  
USA-Shelton CT 06484  
Tel. +1 203 929 9930  
Fax +1 203 929 9949  
E-Mail: treifusa@treif.com

TREIF U.K. Ltd.  
Genesis House, Poole Hall Road,  
Poole Hall Industrial Estate  
Ellesmere Port, GB-Cheshire CH66 1ST  
Tel.: +44 (0) 151 3506100  
Fax: +44 (0) 151 3506101  
E-Mail: treifuk@treif.com

TREIF Italia S.r.l.  
Via Sant'Agnesa 43-45  
40132 Bologna, Italia  
Tel.: +39 051 728138  
E-Mail: info.it@treif.com

TREIF S.R.L.  
22, rue des Tuileries  
F - 67460 Souffelweyersheim  
Tel.: +33 3 88184018  
Fax: +33 3 88184019  
E-Mail: info-france@treif.com

TREIF in Belgium  
Villalaan 21  
B-9320 Raist  
Tel.: +32 53 770813  
Fax: +32 53 789666  
E-Mail: jo.luybaert@treif.com

TREIF Sp. z o.o.  
ul. Jana Kochanowskiego 49  
01-864 Warszawa  
tel: +48 506 412 522  
service: +48 506 413 197  
E-Mail: infopl@treif.com

www.treif.com



DESCUBRE MÁS EN

www.taglermaq.cl